

# Bridge Rectifier

## **2W01G**

100V / 1,5A

# DATASHEET

OEM – General Semiconductor

Source: General Semiconductor Databook 1998

# W005G THRU W10G

## GLASS PASSIVATED SINGLE-PHASE BRIDGE RECTIFIER

Reverse Voltage - 50 to 1000 Volts Forward Current - 1.5 Amperes

Case Style W0G

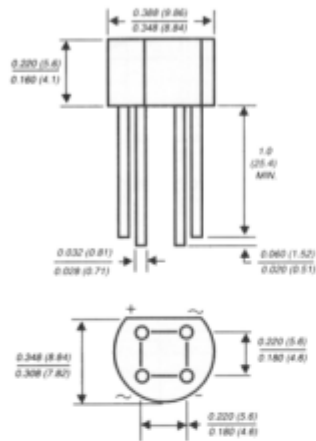

Dimensions in inches and (millimeters)

### FEATURES

- ◆ Plastic material has Underwriters Laboratory Flammability Recognition 94V-0
- ◆ This series is UL listed under the Recognized Component Index, file number E54214
- ◆ Glass passivated chip junctions
- ◆ High case dielectric strength
- ◆ Typical  $I_R$  less than 0.1  $\mu$ A
- ◆ High overload surge capability
- ◆ Ideal for printed circuit boards
- ◆ High temperature soldering guaranteed: 260°C/10 seconds, 0.375" (9.5mm) lead length, 5lbs (2.3kg) tension



### MECHANICAL DATA

**Case:** Molded plastic body over passivated junctions  
**Terminals:** Plated leads solderable per MIL-STD-750, Method 2026  
**Mounting Position:** Any  
**Weight:** 0.04 ounce, 1.1 grams

### MAXIMUM RATINGS AND ELECTRICAL CHARACTERISTICS

Ratings at 25°C ambient temperature unless otherwise specified.

	SYMBOLS	W005G	W01G	W02G	W04G	W06G	W08G	W10G	UNITS
Maximum repetitive peak reverse voltage	VRRM	50	100	200	400	600	800	1000	Volts
Maximum RMS voltage	VRMS	35	70	140	280	420	560	700	Volts
Maximum DC blocking voltage	VDC	50	100	200	400	600	800	1000	Volts
Maximum average forward rectified current at 0.375" (9.5mm) lead length at TA=25°C	IAV	1.5							Amps
Peak forward surge current single sine-wave superimposed on rated load (JEDEC Method)	IFSM	50.0							Amps
Rating for fusing (t<8.3ms)	I <sub>t</sub>	10.0							A <sup>2</sup> sec
Maximum instantaneous forward voltage drop per leg at 1.0A	VF	1.0							Volts
Maximum DC reverse current at rated TA=25°C DC blocking voltage per leg TA=125°C	IR	5.0 500.0							$\mu$ A
Typical junction capacitance per leg (NOTE 1)	CJ	14.0							pF
Typical thermal resistance per leg (NOTE 2)	REJA REJL	36.0 11.0							°C/W
Operating junction temperature range	TJ	-55 to +150							°C
Storage temperature range	TSTG	-55 to +150							°C

**NOTES:**

- (1) Measured at 1.0 MHz and applied reverse voltage of 4.0 Volts
- (2) Thermal resistance from junction to ambient and from junction to lead at 0.375" (9.5mm) lead length P.C.B. mounting

**RATINGS AND CHARACTERISTICS CURVES W005G THRU W10G**

